

# **PROTECTION METHODS TO COMBAT THE CORROSION OF STEEL PILINGS - CASE STUDY OF HAI PHONG PORT IN HAI PHONG CITY, VIET NAM**

Dr. Nguyen Thanh Son

MSc. Le Thi Le

Vietnam Maritime University, Hai Phong City, Vietnam

e-mail: nthson@vimaru.edu.vn

**Abstract:** Since steel piling firstly used in 1908 at Black Rock Harbour (USA), nowadays its variety of sizes and shapes has been applied widely and more popular especially in marine constructions such as piers, jetties, wharves, embankments, breakwaters, offshore drilling platforms, etc. Although there are a lot of advantages to use steel piling in constructions, the biggest issues needs to be solved to effectively protect them in the high corrosive environment like sea water.

Hai Phong old port, which is located just outside Hai Phong downtown, was built by steel piling since 1960s. The port has been playing an important role as a main gate of the North of Viet Nam for a long time. As over 50 years of operation, its steel piling wall has been degraded caused by the corrosion.

Presently, there are various kinds of protection methods to combat corrosion of steel piling sheet including three (03) main groups as the encasement of steel in concrete (referred to as "concrete jacket"), the protective coatings and cathodic protection (abbreviated to as "CP") . As the corrosion causes, the suitable solutions will be selected and applied. The paper discusses about the cathodic protection as the most appropriate supplementing protection method for Hai Phong old port.

**Keywords:** Hai Phong port; Steel piling; Marine structure; Corrosion protection; Cathodic protection.

## **1. Introduction**

### **1.1. Information**

Hai Phong old port has the berth length 1,717 m. As the initially designed capacity, the port could receive vessels with the tonnage up to 10,000 DWT. As the rapid socio - economics development of Hai Phong City and the Northern economic region as well, the Hai Phong

present port is extended year by year toward ocean with the deeper water area for cargo shipping. And the old port is planned to convert to passenger terminal.

The port is the one of earliest marine construction used the steel piling sheets. To combat the corrosion, the current applied corrosion protection methods are encasing the steel piles in concrete and the combined protective coatings. The encasing concrete jacket used as the heading beam is both to combat corrosion in the fluctuating water and the berthing place. The concrete jacket is produced by the fresh concrete grade 300. The top of beam is at the height 4.05 m and the bottom at the height +0.40 m.

As over 50 years of operation, the steel piling system of the old port has been degraded caused by the corrosion. At present, the average thickness of steel sheet is approximately 18.50 mm, reduced 2.50 mm as compared with the initial design; the corrosion rate is 0.06 mm per year. In order to ensure the good working condition of the port and its durability, it's so necessary to have the more effective protection methods other than the old to combat the corrosion of the marine structure in the seawater.



**Figure 1.** The plan of Hai Phong old port including 11 berths

**1.2. Situation [1]**

The port has totally 11 berth segments. The survey and evaluation are made for the berths No. 7 and No. 8 with the data of the larsen V steel thickness in the following table:

**Table 1:** Survey data of the larsen V steel thickness of Hai Phong port

No.	Berth	Year (Built-Survey)	Duration of operation	Corrosion rate (mm/year)	Thickness of steel piling sheet corroded (mm)	Thick steel piling left (mm)
1	Number 7	1973 - 2015	42	0.062	2.108	18.892

2	Number 8	1973 - 2015	42	0.062	2.046	18.954
---	----------	-------------	----	-------	-------	--------

Over time, the key wall system of Haiphong main port by Larsen V steel piling sheet would be corroded more and more and the corrosion rate has increased. This problem may cause to reduce of bearing capacity and lifetime of the port. Thus, solutions should apply corrosion protection methods soon to protect the old system and other parts of the steel piers under Hai Phong main port.

## **2. Corrosion protection methods**

The current applied corrosion protection methods can be divided into three main groups including the application of various protective coatings, the encasement of steel in concrete and cathodic protection. Actually, the various combinations of 03 mentioned methods could be considered to enhance the effectiveness of corrosion combat. The following paragraphs shall discuss on the advantages, disadvantages and the application scope of each method in order to propose the most suitable one for corrosion protection.

### **2.1. Protective Coatings**

Protective coatings on steel piling are intended to act as a barrier to separate the steel surface from its corrosive environment. The development of suitable coatings for long-term protection of steel in seawater has been quite slow. There are numerous types of coatings now in existence, many of which are used in combination with other types as well as alone. Types of coatings in use today may be divided into a number of categories. The most common categories are metallic and nonmetallic.

*The protective coating method has the following main advantages:*

- Simple, low cost, popular and diversified materials;
- The fabrication process can be made in the factory, so it is convenient to apply the industrialization process and time saving.

*However, this protection method owns outstanding disadvantages to marine constructions as follows:*

- Its application to the steel components submerged in water or soil or tidal areas is so hard especially in maintenance and repair;
- Easily getting damage during the construction process, especially in the high friction between the steel components and the environment such as soil, mud, etc.
- Short maintenance period and strongly influenced by the hot and humid weather condition in Viet Nam;

- Low protection efficiency; not suitable for large-scale steel structures, constructions in the high corrosive environment like marine constructions (Eg. seaports, dykes, dam, etc.).

The corrosion protection method by the protective coatings has the mostly wide application scope in the steel structures but it's unfeasible to be used for the steel marine construction lonely. However, it may be combined with other protection methods to improve the effectiveness of corrosion combat.

## **2.2. Concrete jackets [2]**

The method sometimes used for the steel marine structures from corrosion is to encase or jacket the steel in concrete. In order to ensure the effective protection, the concrete must be good in quality, properly placed and cured, and adequate thickness as well.

Concrete jacketing of steel piling has proven very effective when it extends from the top of the piling to under low water level to be the compatible berthing beam. Though this protection method has been used early, but it only gets much the effective protection to steeling encased directly by concrete. Its effective range in the corrosion protection is quite narrow and almost impossible apply to whole steel structures. Besides, the concrete encasement method can significantly increase the unwanted load to the construction. The ability of preventing collision is its weakness and the flexibility in exploitation, maintenance and replacement is not good as well. Its construction process is also complex, costly, long and requiring the auxiliaries and sub-constructions. And it may affect the exploitation conditions of the flow in the marine constructions.

## **2.3. Cathodic protection [4]**

Cathodic protection is another method of mitigating the corrosion of steel piling in seawater. This method is suitable for protecting the immersed zone of the piling. Corrosion of steel is an electrochemical process which takes place in a corrosion cell. Electrodes of corrosion cells are either cathodic or anodic. The electric current leaves the metal surface at the anode and travels through the electrolyte to the cathode by ion transfer. Corrosion of the metal occurs at the anode where the electric current leaves the metal.

The anodic metal corrodes as current flows to the cathode. The principle is illustrated in Figure 2. In the electrolytic system, direct current electricity of sufficient magnitude is supplied by an outside source. The source is usually a rectifier, which converts alternating current electricity to direct current which flows from one or more anodes through the electrolyte to the metal being protected.

Actually, the cathodic protection (CP) is divided to two types including the galvanic anode CP systems and the impressed current CP system. For galvanic anode CP systems, the anode

of the electrochemical cell is a casting of an electrochemically active alloy (normally aluminium, zinc or magnesium based). This anode is also the current source for the CP system and will be consumed. Accordingly, it is often referred to as a sacrificial anode. For the impressed current CP system, an inert (non-consuming) anode is used and the current is supplied by a rectifier.

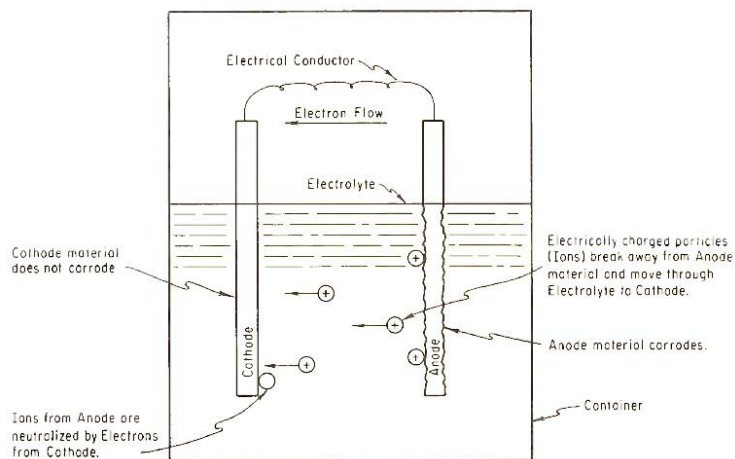

**Figure 2.** Principle of Galvanic Corrosion Cell [2]

For permanently installed offshore structures, galvanic anodes are usually preferred. The design is simple, the system is mechanically robust and no external current source is needed. In addition, inspection and maintenance during operation can largely be limited to periodic visual inspection of anode consumption and measuring the potential using the reference electrode. However, due to weight and drag forces caused by galvanic anodes, impressed current CP systems are sometimes chosen for permanently installed floating structures.

The cathodic protection is applicable for all types of metals and alloys commonly used for subsea applications. It prevents local corrosion forms as well as uniform corrosion attack, and eliminates the possibility for galvanic corrosion when metallic materials with different electrochemical characteristics are combined. This method is primarily intended for metal surfaces permanently exposed to seawater or marine sediments. Still, it is often fully effective in preventing any severe corrosion.

In order to comprehensively enhance and improve the corrosion protection effectiveness for the marine steel structure, the cathodic protection can be combined with the protective coatings and the concrete jackets to reduce the area requiring protection also.

#### **2.4. Proposed corrosion protection method**

The Hai Phong old port has been exploited for a long time, and the corrosion of steel piling wall has appeared with the rate faster and faster overtime. Besides, the port also applied the corrosion protection methods as the protective coatings and the concrete jackets, so it is currently impossible to reuse these methods. It is necessary to apply the other effective method

to reduce the corrosion rate and ensure the operation conditions. The cathodic protection using sacrificial anode system is recommended and proposed to use for the Hai Phong old port because its simplicity and efficiency. Also, it is most suitable for marine structure.

### **3. The tentative application of the cathodic protection using galvanic anodes for Hai Phong old port**

The application is made for the berths No.7 and No. 8 with the technical specifications [1] as follows:

- The length of each berth: 163.6 m;
- The top altitude: +4.50 m (following the sea chart measure);
- The bottom altitude: -8.70 m.
- The designing altitude of the high water level: +3.5 m;
- The designing altitude of the low water level: +0.6 m.

The structure is the steel piling soft wall by V Larsen steel piles which have the length of 22 m. Their bottom altitude is -20.0 m and the top is +2.0 m. The part of steel pile under sea-water has been coated by two layers of ground-coat paint and anticorrosive paint.

In order to combat the corrosion of the steel piling sheet, the reinforced concrete M300 has been applied from the altitude +4.50 to +0.40 to be compatibly used as the berthing place.

The corrosion protection method applied for the steel piling wall to lengthen lifetime and ensure the operation condition of is the galvanic anode CP system. Before calculating and designing the galvanic anode system, the input data need to be determined including:

- Specifications of steel piling sheet;
- Requirement for the corrosion protection system meaning the lifetime of sacrificial anodes;
- Specification of combining protective coatings;
- Natural conditions;
- Sea-water at the construction place, etc.

The galvanic anode CP system is calculated and designed in the following procedures [3]:

#### **3.1. Surface area calculations needed to be protected**

The surface areas require CP shall be calculated separately for surfaces which influence the CP current demand. For the larsen steel piling sheet, the surface is determined by the following formula:

$$A_c = L * H_c * f \quad (1)$$

*In which:*

$A_c$ : the surface area need to be protected ( $m^2$ );

$L$ : overall length of steel pile (m);

$H_c$ : the height of the piles in the CP range (m)

$$H_c = H_{c, \text{water}} + H_{c, \text{soil}}$$

$H_{c, \text{water}}$  = (Height of pile head - Height of mud bottom);

$H_{c, \text{soil}}$  = (Height of mud bottom - Height of pile bottom);

$f$ : The extension coefficient of steel piles ( $f = 1.9$ ).

### 3.2. Current demand calculation

The current demand  $I_c$  (A) is calculated by the formula:

$$I_c = A_c * i_c * f_c \quad (2)$$

*In which:*

$A_c$ : the surface area need to be protected ( $m^2$ );

$i_c$ : the required current intensity ( $A/m^2$ );

$f_c$ : the coefficient of paint peeling is calculated as follows:

$$f_c = a + b * t \quad (3)$$

$a, b$ : constants depending on the characteristics of the paint and the environment

$t$ : usage time (determined each years)

### 3.3. Anode Mass Calculations

The total net anode mass,  $M$  (kg), required to maintain cathodic protection throughout the design life,  $t_f$  (yrs), is to be calculated from  $I_{cm}$  (A) for each unit of the protection object (including any current drain):

$$M = \frac{I_{cm} * t * 8760}{u * \varepsilon} \quad (4)$$

In (3.4), 8760 refers to hours per year;  $u$  - coefficient of using anode ( $u = 0.9$ );  $\varepsilon$  - Electrochemical capacitance of material ( $\varepsilon = 2500$  Ah/kg in seawater).

### 3.4. Calculation of number of anodes

From the anode type selected and the number of anodes, anode dimensions and anode net mass shall be defined to meet the requirements for:

- Initial/final current output,  $I_{ci}/ I_{cf}$  (A);
- Anode current capacity  $C_a$  (Ah)

which relate to the CP current demand,  $I_c$  (A), of the protection object.



a) Cylinder

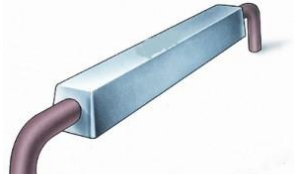

b) Trapezoid



c) Semi-annular

**Figure 3.** Common types of sacrificial anodes

The types of cylinder and semi-annular shapes are suitable for steel pipe structures. Trapezoid is preferred to use for other steel surface. For the V larsen steel piles of Hai Phong port, the trapezoid type of the galvanic anode CP system (Long Slender Stand-Off type) is selected to use.

### 3.5. Calculation of suitability of sacrificial anode

The current capacity of each anode is calculated by the following formula:

$$I_a = \frac{E_c^o - E_a^o}{R_a} \quad (5)$$

Where as:

$E_c^o$ : the design protective potential;

$E_a^o$ : the design closed circuit potential of the anode material.

The Anode resistance is determined by the selected anode type. For an anode of the Long Slender Stand-Off type, the resistance of the anode is calculated according to the formula (DNV B401 standard):

$$R_a = \frac{\rho}{2 * \pi * L} \left( \ln \frac{4L}{R} - 1 \right) \quad (6)$$

Where as:

$\rho$ : sea water resistivity 0.23 ( $\Omega\text{m}$ );

L: length of anode (m);

R: Radius of anode (m) for round anode;

$R = C/2\pi$  for anodized rounded anodes (C is the anode cross sectional area).

The beginning current ( $I_{ai}$ ) and the end ( $I_{af}$ ) of each anode shall be determined by (5) and (6).

When the sacrificial anode has dissolved to the effective coefficient, the remaining volume of the anode at the last moment is calculated as follows:

$$m_{af} = m_{ai} * (1-u) \quad (7)$$

The length of anode at the last moment ( $L_f$ ):



$$L_f = L_i - 0.1 * u * L_i \quad (8)$$

The last radius of the anode:

$$r_{final} = \sqrt{\frac{m_{ai}(1-u)}{\pi * density * L_f} + r_{core}^2} \quad (9)$$

In the case the results of the anode currents at the beginning and the end are greater than the required protective currents on the steel piles:  $I_{ai} > I_{ci}$  and  $I_{af} > I_{cf}$ , this asserts shape, size and volume of the anode meets the requirement for the protective current for the building up to 90% of its design life time.

### 3.6. The installation of sacrificial anode

- The distance of installation is from the lowest water level to the upper point of the anode;
- The anode spacing can fluctuate within  $\pm 1$  m;
- Visual inspection to remove or repair damage during transportation prior to installation;
- Welding anode directly to the steel pile, the weld should be checked to ensure the weld characteristics according to the specified standards.

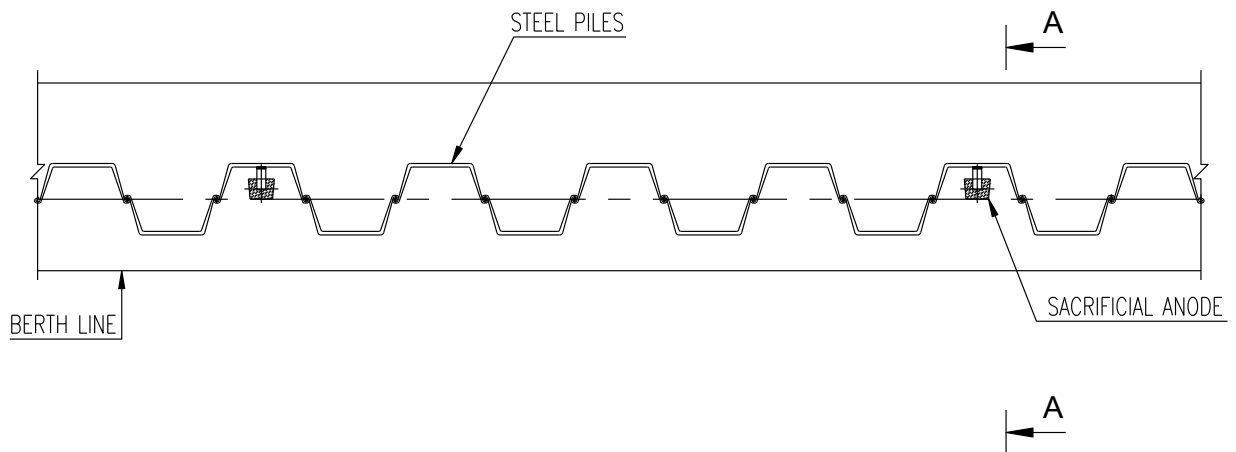

**Figure 4.** Arrangement of sacrificial anodes in the plan

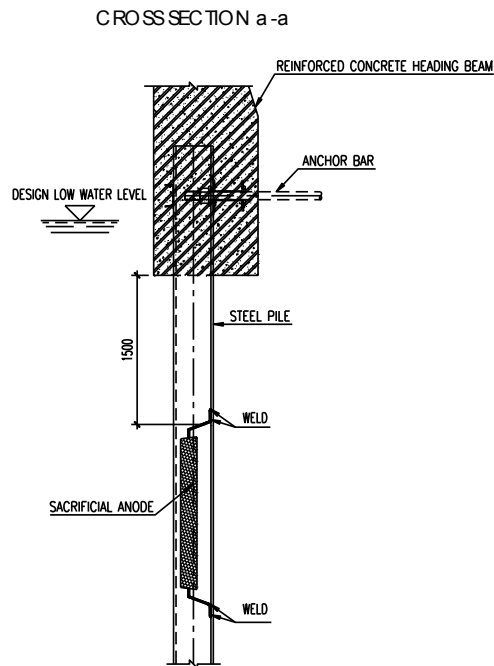

**Figure 5.** Installation of sacrificial anodes in the cross section

#### 4. Conclusion

As the long-time operation of Hai Phong port, the steel piling system has been corroded with the faster rate over time though it has been protected by the concrete jacket and the protective coatings. As discussed above, the protective coatings are so restricted to the steel components submerged in soil, water and tidal areas. And it's easily damaged in the construction process when the high friction between steel and environment (such as soil, mud) appears. Its application to the marine construction which requires the high protection efficiency can be only the supplement to the overall protection. The concrete jackets may provide the higher local protection, but it is only effective to the directly encased components by concrete and unfeasible to be used for whole construction. Moreover, the major failures can appear when collisions occur. Though these two protection methods are lower cost and simpler, they are unsuitable and difficult to the in-service marine constructions by their limited range protection.

By discussing and analyzing three corrosion protection methods above, the cathodic protection is proposed as the most effective and active corrosion combat for marine structures especially the in-service construction such as Hai Phong port. For case study of Hai Phong port, the galvanic anode CP system using the Long Slender Stand-Off type with the trapezoid cross is recommended by the addressed outstanding advantages including the high protection efficiency, the good corrosion control and the flexibility in maintenance and operation as well. This method is proposed and designed for significantly enhancing and improving its lifetime and durability of the Hai Phong port system.

## References

- [1] Hai Phong port, *The periodical report of the quality verification - The berths No. 7 and No. 8 of Hai Phong port*, 2015;
- [2] Laverne L. Watkins, Section VII, *Corrosion and protection of steel piling in seawater*, US Army Corps of Engineers, Coastal Engineering Research Center, May 1969, Technical Memorandum No. 27;
- [3] Det Norske Veritas, *DNV RP - B401 Standards: Cathodic Protection Design*, October 2010;
- [4] Carl A. Thoresen, Part 16, *Port Designer's Handbook*, Institution of Civil Engineerings, 2014, Third Edition;
- [5] European Commission, Final report, *Design method for steel structures in marine environment including the corrosion behaviour*, 2007, EUR 22433.