

P r o c c e e d i n g s
16th IAMU Annual General Assembly
Opatija, Croatia, 2015



Sveučilište u Rijeci
Pomorski fakultet Rijeka
University of Rijeka
Faculty of Maritime
Studies Rijeka



IAMU

International Association of Maritime Universities

ENERGY EFFICIENCY ANALYSIS OF PUMP SYSTEMS IN A SHIP POWER PLANT AND A CASE STUDY OF A CONTAINER SHIP

Durmusoglu, Yalcin*; Kocak, Gazi; Cengiz, Deniz; Zincir, Burak

Istanbul Technical University,
Maritime Faculty, Department of
Marine Engineering
Turkey

Abstract. Energy efficiency can be defined as the reduction of energy consumption per unit of service or product quantity that without causing a decline in the quantity and quality of production which the standard of living of the people and service quality, and industrial enterprises. In the other hand an energy efficiency is prevent energy losses in the gas, steam, heat, air and electricity; or to reduce the demand for energy without reducing the production recovery and evaluation or advanced technology of various waste, more efficient energy sources, advanced industrial processes, activities such as energy recovery is the whole of the building measures.

It is well known that the most of the electricity energy is consumed by the pump for applications at the buildings, industry and transportation. A research study, among the consume energy machinery, have illustrated that pumps are used the energy in 20%. Due to that pumps and pump systems have a great importance in term of energy efficiency in the different sectors.

There are many type of pumps and pump systems for different purposes in ships. They are often worked at full load in cruising, maneuvering and hotelling conditions. Therefore unnecessary energy consumption is realized. It is demonstrated that some simple measures or some minor changes can be saved energy between 20% and 30% in the industrial application from the pump systems. Accordingly, it may be mentioned from such a large energy savings potential from the ships.

In this paper, the energy consumption of pumping system of a container ship at the full ahead, half ahead and slow ahead situations are calculated. The pumping system's energy saving improvements and its effect to ship's annual energy consumption are calculated for the same ship, and the economic gain and efficiency increases are discussed.

Key words: container ship, energy cost, energy efficiency, marine power plant, pump

***Corresponding author**

Phone: +90.395.1064

Fax: +90.216.395.4500

e-mail: ydurmusoglu@itu.edu.tr

1 INTRODUCTION

The marine transportation sector is one of the major causes of global air pollution. Shipping emissions affect global air quality, people's health, the marine ecology, and global warming. Carbon dioxides (CO_2), carbon monoxide (CO), particulate matter (PM), nitrogen oxides (NO_x), and sulfur oxides (SO_x) are the most significant pollutants emitted from marine diesel engines. Emitting CO_2 from maritime transportation is responsible 3.3% of world total CO_2 emissions. Due to increased global fleet and freight volumes, they are predicted to increase by 150%-250% by 2050 [1]. By this reason, IMO is studying on some new regulations to reduce CO_2 emissions from shipping. There has been developed some techniques for reducing CO_2 emissions from shipping with an agreed timetable for adoption. An Energy Efficiency Design Index (EEDI) was set minimum limits on the emissions of CO_2 per unit of transport work from newly built vessels, and Ship Energy Efficiency Management Plan (SEEMP) was developed for all new and existing ships to improve awareness for energy efficiency and to reduce fuel consumption and CO_2 emissions.

Energy and environmental efficiency is today one of the key capability factors for ship operators and therefore these aspects also have to be one of the core elements in ship design process. From main engine to cargo operations, energy efficiency has become the base to set up and plan any machinery or procedure. A number of components on board require electric or mechanical power. Pumps are often a major consumer in this category. A vessel's cooling water system is one of the main consumers among the auxiliary systems,

requiring roughly a third of the electrical energy on board. The cooling water system consisted of three subsystems: the sea water (SW) cooling system, the low-temperature (LT) fresh water cooling system and the high-temperature (HT) fresh water cooling system. The SW system employed sea water to cool down the water of the LT circuit. The sea water pumps are always separate from the engine and electrically driven. The capacity of the pumps is determined by the type of coolers and the amount of heat to be dissipated.

In this paper, the energy consumption of pumping system of a container ship at the full ahead, half ahead and slow ahead situations are calculated. The pumping system's energy saving improvements and its effect to ship's annual energy consumption are calculated for the same ship, and the economic gain and efficiency increases are discussed.

2 PUMPS AND SHIP PUMP SYSTEMS

2.1 Pump, pump systems and pump efficiency

A pump is a device that moves fluids or sometimes slurries, by mechanical action. Pumps can be classified into three major groups according to the method they use to move the fluid: direct lift, displacement, and gravity pumps. Pumps operate by some mechanism (typically reciprocating or rotary), and consume energy to perform mechanical work by moving the fluid. Pumps operate via many energy sources, including manual operation, electricity, engines, or wind power, come in many sizes, from microscopic for use in medical applications to large industrial pumps [2]. Typical pumps assembly is shown in Figure 1. As it can be seen

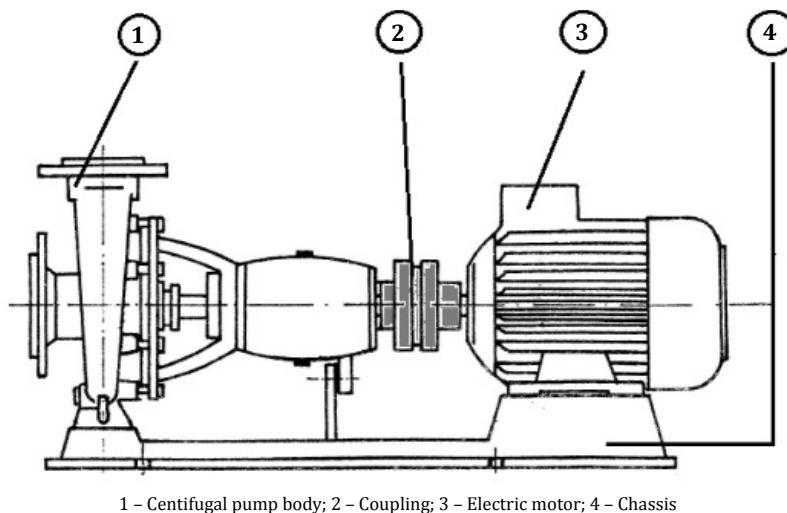

Figure 1 A typical pump arrangement

in figure, a pump system consists of some parts. First part is a pump body which is actuated a fluid inside of its body. The second part is an electrical driver (motor) that supply power for the pump. Third part is a coupling that connects the pump body with the electric motor. All this equipment installed on a chassis that is the fourth part. Also there are some another parts for example pipes and fitting equipment that are not shown in figure 1.

Also a pump system should be works with efficiency. Pump efficiency is defined as the ratio of the power imparted on the fluid by the pump in relation to the power supplied to drive the pump. Its value is not fixed for a given pump efficiency (η) is a function of the discharge (Q , mass flow in cubic meter per hour or sometimes in liter per hour) and therefore also operating head (H) in meter [3].

For centrifugal pumps, the efficiency tends to increase with flow rate up to a point midway through the operating range (η_{opt}) and then declines as flow rates raise further. Pump performance data such as this is usually supplied by the manufacturer before pump selection (Figure 2). The efficiency of the pump depends upon the pump's configuration and operating conditions (such as rotational speed, fluid density and viscosity etc.) [4].

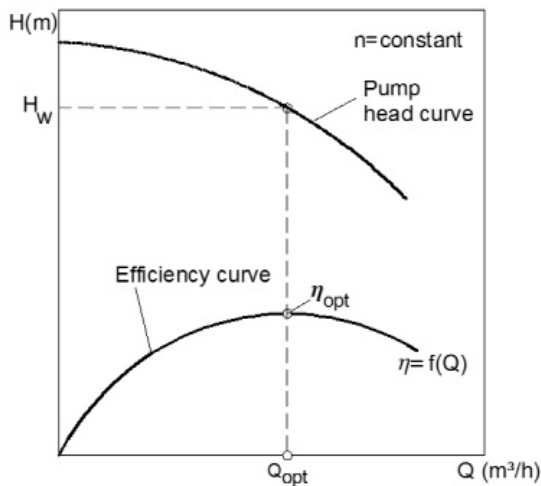

Figure 2 Performance diagram of a pump

The power of pump shaft and the power of electric motor's shaft equations are shown in follow.

$$P = \frac{rQH}{367h} \text{ (kW)} \tag{1}$$

$$P_M = a \times P \text{ (kW)} \tag{2}$$

Where ρ is specific mass in kg/m^3 ; Q is mass flow in m^3/h ; H is head in meter, α is a multiply factor is given in Table 1.

Table 1 The multiply factor for equation 2 [2]

P(kW)	α
< 1.5	1.50 - 1.40
1.5 - 4	1.40 - 1.25
4 - 35	1.25 - 1.15
> 35	1.15 - 1.10

2.2 Ship pump systems

Pumps are used to different aims for various plant on shps. The ship systems consist of a fresh water (F/W) cooling system, sea water (S/W) cooling system, luboil (L/O) system, fuel system (F/O and D/O), balast system, bilge system, sludge system hydrophore system and fire fighting system in ships. Therefore it can be say that there are some different kinds of pumps (Table 2). However the centrifugal pumps are the most common used type of pumps on ship applications [5].

Table 2 Some type of pumps on ships

Systems	Quantity of pumps	Types of pumps
HTFW cooling system	2	Centrifuge
LTFW cooling system	2	Centrifuge
SW cooling system	2	Centrifuge
Fire system	2	Centrifuge
Hydrophore system (S/W,F/W)	6	Centrifuge
F/O,D/O transfer system	3	Screw
L/O system (M/E, D/G)	3	Screw
L/O system (M/E, D/G)	6	Centrifuge
Bilge and sludge system	1	Centrifuge
Bilge and sludge system	1	Screw
Bilge and sludge system	1	Piston

The sea water pumps is the most important pumps include cooling service for a ship and such ship service systems as ballast and fire main. The main sea water cooling system will normally consist of two supply pumps and distribution piping. The system may supply water to the main engine L/O coolers, main engine F/W coolers and main engine air coolers services. On tankers the main sea water cooling system may also serve a condenser for cargo and ballast pump turbines.

According to tropical condition standards, every cooling pump capacities are designed at 110% more

than normally load condition on ships. This means that pumps are working inefficiency when the ambient conditions are not unsuitable to tropical conditions. The tropical conditions value is shown in table 3. In actualy, the sea water temperature is variability for different region in the world and the ships are constantly cruise from a port to another port. Due to needed cooling capacity is variable. Therefore pumps should be operated for different capacity on ships but it is not suitable yet.

Table 3 Tropical conditions standards for ships

Sea water temperature	32 °C
Central water temperature	36 °C
Ambient air temperature	45 °C
Barometric pressure	1 bar

Changing the fluid temperature are parameters that directly affect the pump performance. However seawater pumps always work according to the initial design value, despite continuously changing fluid temperature. In addition the pump capacity may be reduced further in the ship maneuvering conditions. Thus, in this case it leads to energy loss of the sea pumps.

3 CALCULATION METHODS OF ENERGY EFFICIENCY

This section consists of calculation methods for a sea water pumps. As it well known a great number of pumps are installed on ships. However it was considered only a sea water pump accounts to be easy and straightforward. A sea water cooling pump of a container ship is used in the calculations as an example. The calculation method covers an energy losses calculation, an energy cost accounts and an environmental effects from a sea water pump that installed to consider container ships. The container vessel sea water cooling systems are given in Figure 3 as schematic. Also it is developed a scenario under a case study title for calculation.

Fresh water circuit system is divided two sections which are high temperature fresh water (HTFW) system and low temperature fresh water (LTFW) system. High temperature fresh water system associated with main diesel engine and low temperature fresh water associated with low temperature fresh water coolers which are air coolers, lube oil coolers, air compressor coolers, air conditioning cooler etc. Both high temperature fresh water system and low temperature fresh water system can be connected with three way flow control valve in circuit line. If main engine jacket water temperature is sufficiently lower, the fresh water flows down to the low temperature fresh water and mixed with it. Thus the

jacket cooling fresh water temperature can be decreased and then flow back to the main diesel engine inlet. At same time the low temperature fresh water temperature can be increased. Before the LTFW inlet to the fresh water pump, it is cooled by fresh water coolers. Thus the circuit is completed. If engine jacket water temperature is higher, the fresh water inlet to the fresh water cooler directly and after then cooled, it cross the LTFW pump, LTFW cooler and three way flow control valve and goes to main engine inlet.

The problem is when does the fresh water bypass line is open there is a inefficiency application on the system. Because if some fresh water bypassed the fresh water cooler, the sea water pump which working constant speed and supply a constant quantity mass flow for cooling, high capacity while it is not necessary. This problem will increase further when the main engine speed is decreases. Eventually it can be say that the energy is wasted and therefore very high costs of energy and have an adverse effect on the environment.

A simple calculation method is used for estimating a wasted energy, an energy costs and an environmental effects from sea water pump system on the container ship. The scenario is explained as follow:

The container ship starts to cruise from Istanbul to New York. The distance is approximately 5025 Nautical miles. The container ship's speed is 25 knots. It is assumed that a container ship may cruise nearly 275 day per year. There are maneuvers both of ports and it is assumed approximately 5 hour per one service (Table 4). On the other hand the cruising time is 201 hour per one service by ship. That is the total service time is 206 hour between ports per one service. As a consequently the container ship totally have 6440 hours in cruising mode and 160 hours in maneuver per years. The results are shown in Table 5 in briefly.

Table 4 The data of case study

Distance	5025 NM
Ship speed	25 knots
Maneuver time in Istanbul	2.5 hour/a service
Maneuver time in New York	2.5 hour/a service
Cruising time	201 hour/a service
Total time	206 hour/a service

Table 5 The annually service time on container ships

Total cruising time	6440 hour/year
Total maneuver time	160 hour/year
Total service time	6600 hour/year

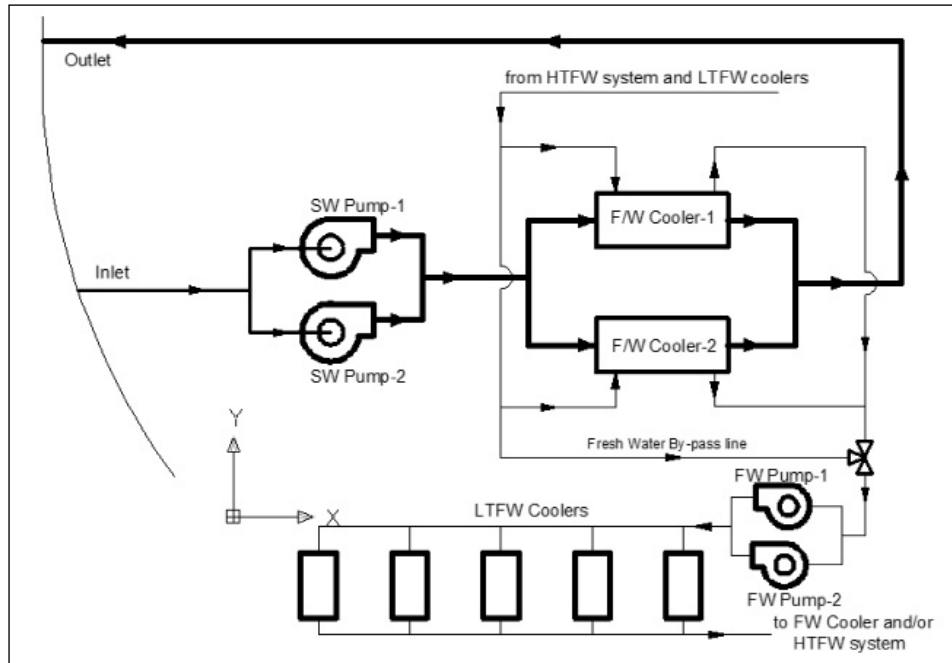

Figure 3 Sea water circuit system of a container ship

Table 6 Data of fresh water cooler inlet and bypass mass flow

$T_D = 20\text{ }^\circ\text{C}$			
M/E loads (%)	M/E speed (rpm)	Inlet mass flow to FWC (t/h)	Bypass mass flow (t/h)
100	102	1219	378
75	80	480	945
50	58	245	995
25	36	94	1120

The fresh water cooler (FWC) inlets and bypass mass flow data is shown in table 6 as a sample for sea water temperature at 20 °C. Also there are same table data's for the different sea water temperature in 18 °C, 15 °C, 13 °C.

Data including in the table 6 is regarding with main engine variable loads. The 100% load means that the main engine is in full speed conditions. The other loads 75%, 50%, 25% is half speed, slow speed and dead slow speed respectively. The inlet fresh water mass coming up from high temperature circuit (HTFW) and/or from low temperature fresh water (LTFW) circuit. When the fresh water temperature is lower, the fresh water mass can be separate to two line. First line is the inlet line to fresh water cooler and the second line is bypass line. By the time the bypass line is open, inlet fresh water mass flow was decrease. Even though to this situation sea water mass flow should be decrease, it is not possible in actually. That means the sea water mass flow is constant. Due to these conditions there is waste energy, waste money and inefficiency operation on the ship's sea water circuit system.

4 RESULTS AND DISCUSSION

For calculation the wasted energy cost and wasted CO₂ which is release to atmosphere there are some assumption. The assumption is 1 kWh electrical energy is equal to 0.65 kg CO₂ and a unit energy price is equal to 0.076 \$/kWh. From this approaches the wasted energy, wasted energy costs and the emissions of CO₂ are calculated and the results are illustrated in tables of 7, 8, 9 and 10.

The wasted energy is 932 MWh per year in totally on the container ship while the sea water temperature is equal to 20 °C. Also it can be understand from the table 7 cost of wasted energy is approximately 71,130 \$ per year in totally. However the ship released about 633,316 tones CO₂ per year to atmosphere due to the waste energy. It is clearly understand that when the main engine speed decreases at first all the parameters decrease to minimize point and after then to increase again. It means that there is a optimum point for main engine speed in term of waste energy and also waste energy cost and CO₂ production on ships.

Table 7 Calculation results for the sea water temperature 20 °C

Main engine loads (%)	Wasted energies (MWh/year)	Wasted energy costs (\$/year)	Released CO ₂ emissions (t/year)
100	382	29,157	14,730
75	60	4,605	14,770
50	124	9,499	62,850
25	365	27,869	540,966
Total	932	71,130	633,316

Table 8 Calculation results for the sea water temperature 18 °C

Main engine loads (%)	Wasted energies (MWh/year)	Wasted energy costs (\$/year)	Released CO ₂ emissions (t/year)
100	626	47,792	39,575
75	66	5,021	17,561
50	145	11,068	85,329
25	436	33,291	771,934
Total	1273	97,172	914,399

Table 9 Calculation results for the sea water temperature 15 °C

Main engine loads (%)	Wasted energies (MWh/year)	Wasted energy costs (\$/year)	Released CO ₂ emissions (t/year)
100	937	71,530	88,652
75	82	6241	27,131
50	178	13,592	128,670
25	636	48,521	1639,814
Total	1833	139,884	1,884,267

Table 10 Calculation results for the sea water temperature 13 °C

Main engine loads (%)	Wasted energies (MWh/year)	Wasted energy costs (\$/year)	Released CO ₂ emissions (t/year)
100	1131	86,303	129,052
75	92	7,042	34,536
50	203	15,498	167,287
25	656	50,043	1,744,267
Total	2082	158,885	2,075,142

The table 8 shows a similar property with table 7. Only the numerous are varies. For instance the wasted energy is 626 MWh per year in totally on the container ship while the sea water temperature is equal to 18 °C. It can be understand from the table 8 cost of wasted energy is approximately 97,172 \$ per year in totally. However the ship released about 914,399 tones CO₂ per year to atmosphere due to the waste energy. If compared the tables of results, it can be say that there are adverse relations between sea temperature and waste energy, waste costs and CO₂ emission release. For instance while the sea water temperature equal to 20 °C, the total waste energy is equal 932 MWh per year; on the other hand while the sea water temperature equal to 18 °C, waste energy increasing about 341 MWh per year.

The table 9 and 10 are also similar with table 7 and 8. The waste energy and waste energy costs are 1833

and 2082 MWh per years in the sea temperature 15 °C and 18 °C, respectively. Additionally, the wasted energy costs are 139,884 \$ per years and 158,885 \$ per years, respectively.

REFERENCES

- [1] Third IMO GHG Study 2014, Final Report. Reduction of GHG Emission Ship, MEPC67/INF.3, 25 July 2014.
- [2] Mete SEN, Fundamentals Comprehensive of Pumps, *Centrifugal Pumps and Pump Piping Systems*, 2006, Chapter 1, 1-17.
- [3] A. Ozden Ertoz, Energy Efficiency in Pumps, VI. National Facility Engineering Conference and Exhibition, 2003, Izmir.
- [4] EUROPUMP-POMPSAD, A Guide for System Efficiency, Pumps with High Level Energy Efficiency.
- [5] Kemal Demirel, Ismail Deha Er, Marine Systems and Circuits, *Pumps Applications*, 2007, 505-543.